



KSMD05PWR/GU10-W

5w SMD LED, GU10, 100°, 30000hrs



Product Overview

The high quality KTC-SMD range is perfect for home, office and hospitality settings with all the environmental and financial benefits of LED technology. Designed as a direct LED retrofit for standard halogen GU10 lamps, the SMD range provides a choice of wattages, including dimmable and low voltage options on some models. The energy saving SMD seamlessly blends into decorative fittings with a stylish lamp body, whilst the PPS Thermally Conductive Plastic provides excellent heat dissipation and electrical insulation making them the ideal choice for many installations.

Features

Save energy up to 90% compared with halogen lamps.

Direct replacement of GU10 halogen lamp.

100° beam angle.

High lumen output.

Unit D2 Kennetside, Bone Lane
NEWBURY, BERKSHIRE

T: 01635 523 713 E: sales@kosnic.com W: <http://www.kosnic.com>

Long life of 30,000hrs.

Instant start.

Negligible UV output.

Mercury free.

Specifications

Fitting	GU10
Shape / Type	PAR16
Colour Finish	Silver
Materials	PPS Thermally Conductive Plastic
Optics Type	Reflector
Wattage (w)	5
Input Current (mA)	40
Input Voltage	220-240Vac
Rated Life (hrs)	30000
Switch Cycles	50000
Beam Angle (°)	100
Dimmable?	No
Retrofit?	Yes
Power Factor	0.54
Start Time (s)	0.4
Warm-up Time (s)	0.42
Length (mm)	54
Width (mm)	50
Depth (mm)	50
Ambient Temperature (°C)	-20 to 40

Unit D2 Kennetside, Bone Lane
NEWBURY, BERKSHIRE

T: 01635 523 713 E: sales@kosnic.com W: <http://www.kosnic.com>

Energy Label

Energy Class A+

Energy Consumption (kWh/1000h)

5

Packaging

Outer Box Length (mm) 575

Outer Box Width (mm) 285

Outer Box Height (mm) 157

Volume 0.025728375

Box Quantity 100

Outer Box Weight/kg 7

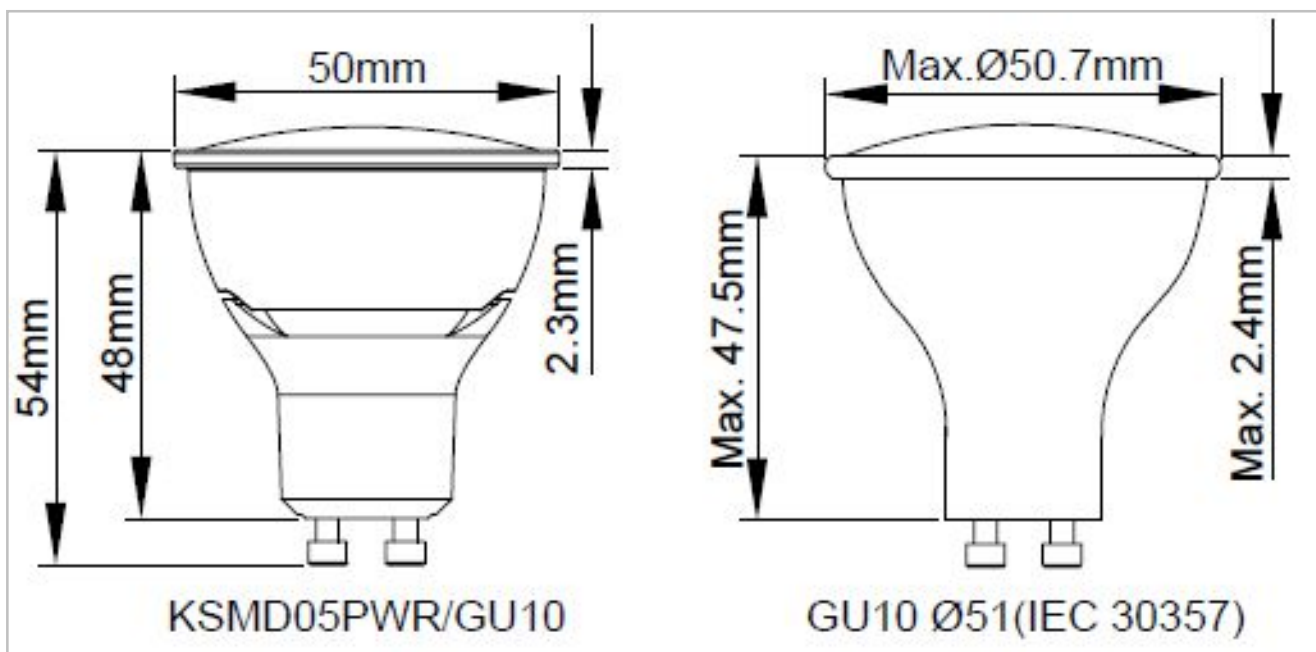

Datasheet generated from <http://www.electrika.com> on Sunday, May 14, 2017 8:08:46 PM